

# European Judo Cup Orenburg 2015

Orenburg (RUS), 16-17 May 2015

## -60 kg

28 Judoka

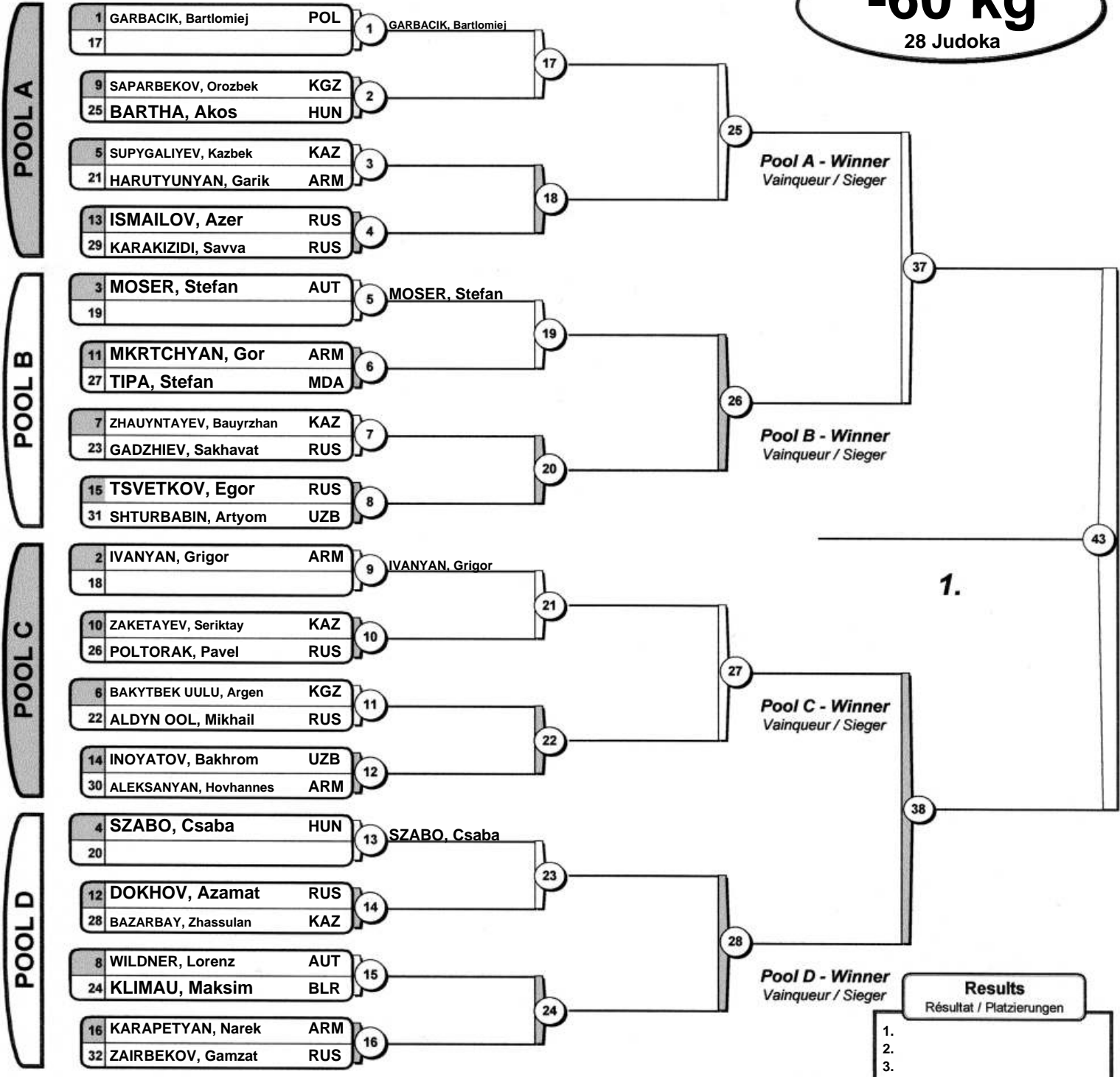

1.

**Results**  
Résultat / Platzierungen

- 1.
- 2.
- 3.
- 3.
- 5.
- 5.
- 7.
- 7.

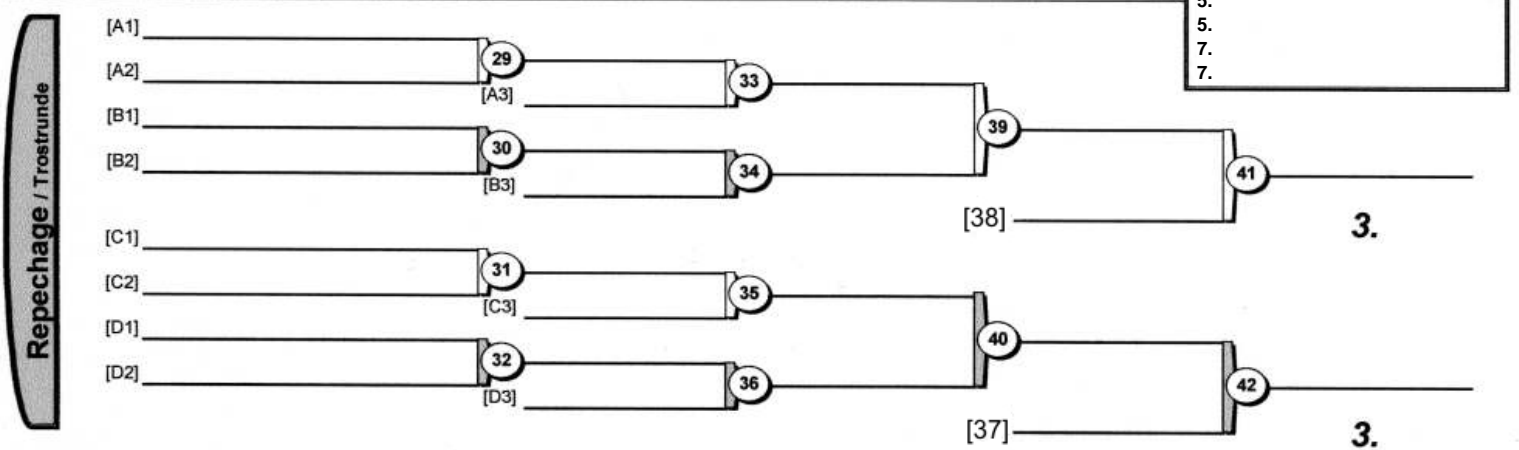

# European Judo Cup Orenburg 2015

Orenburg (RUS), 16-17 May 2015

## -66 kg

34 Judoka

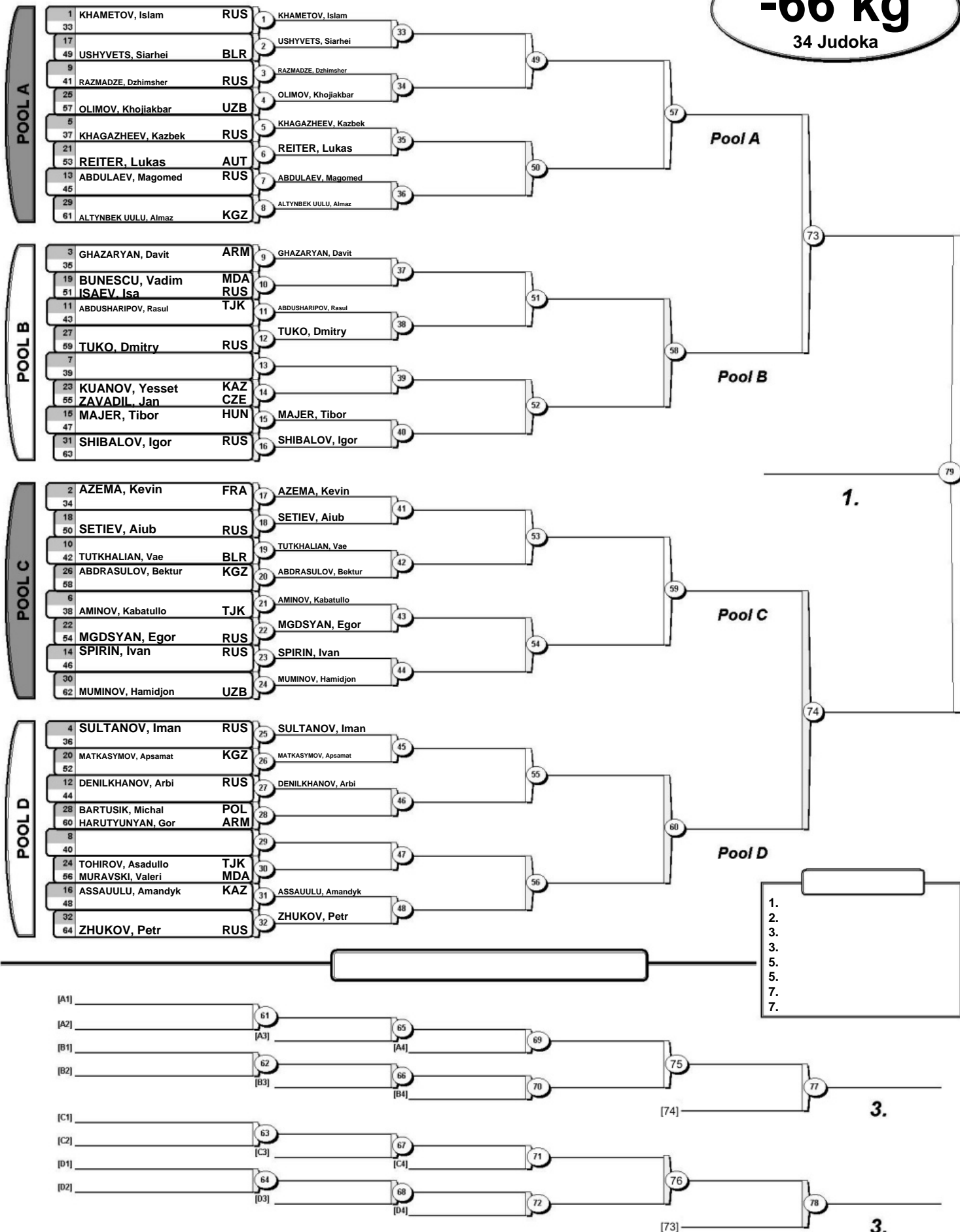

# European Judo Cup Orenburg 2015

Orenburg (RUS), 16-17 May 2015

## -73 kg

32 Judoka

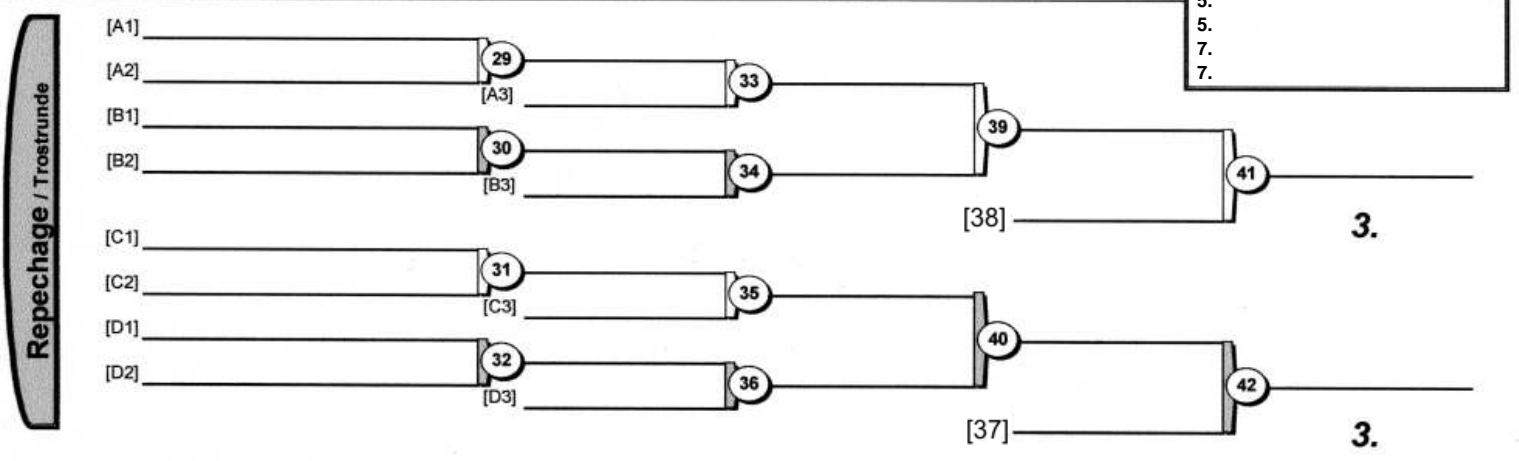
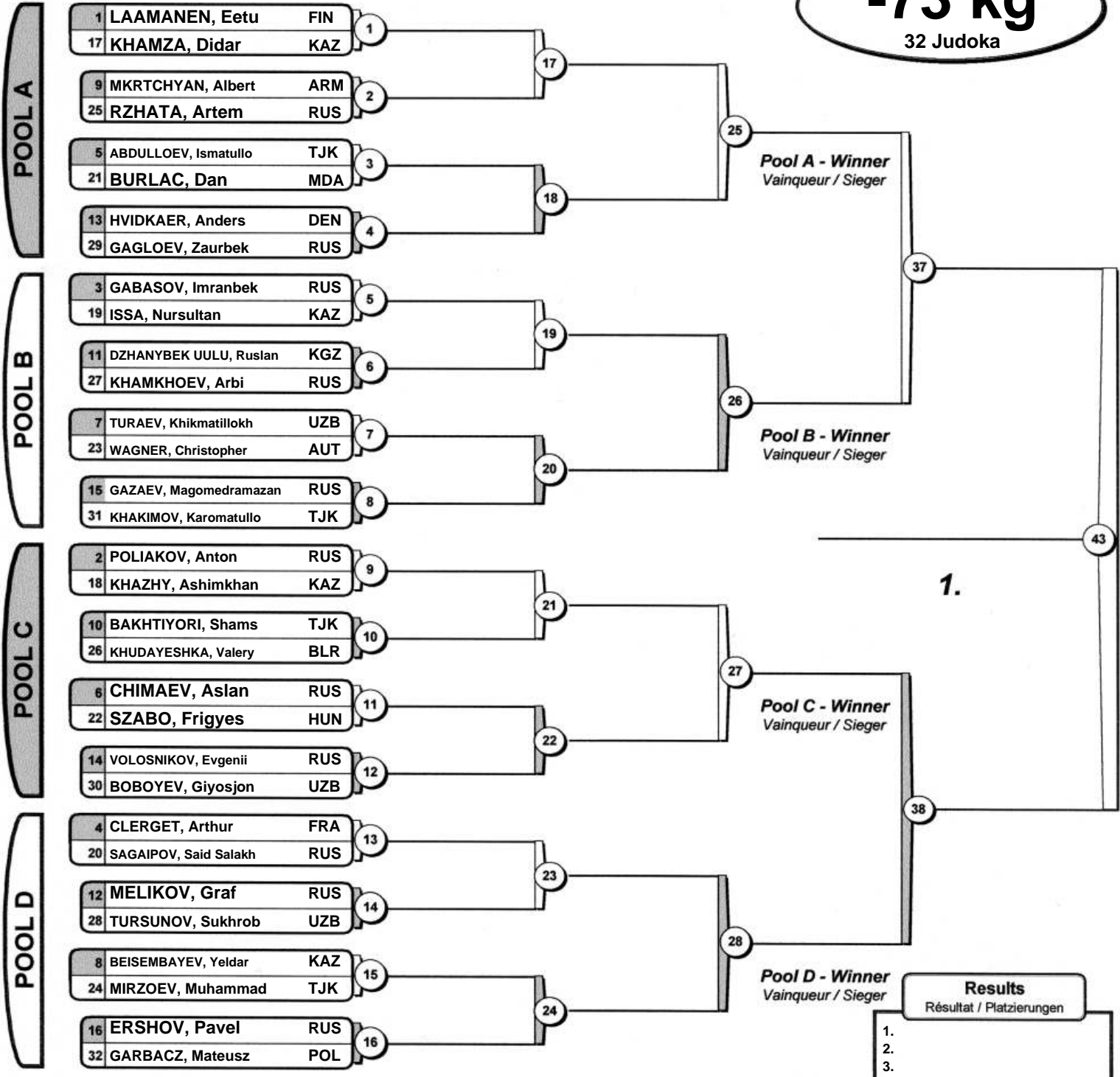

# European Judo Cup Orenburg 2015

Orenburg (RUS), 16-17 May 2015

## -81 kg

26 Judoka

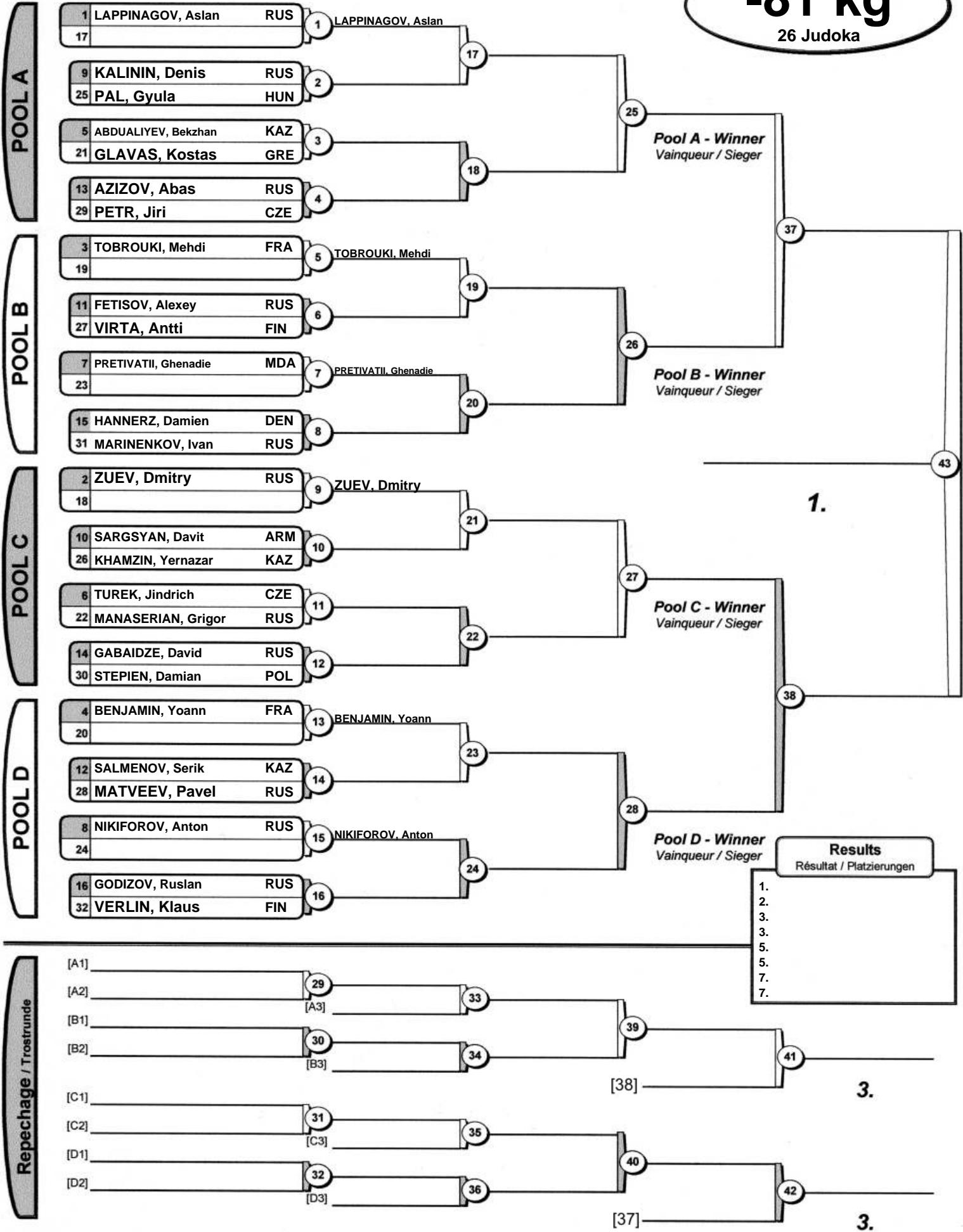

# European Judo Cup Orenburg 2015

Orenburg (RUS), 16-17 May 2015

## -90 kg

27 Judoka

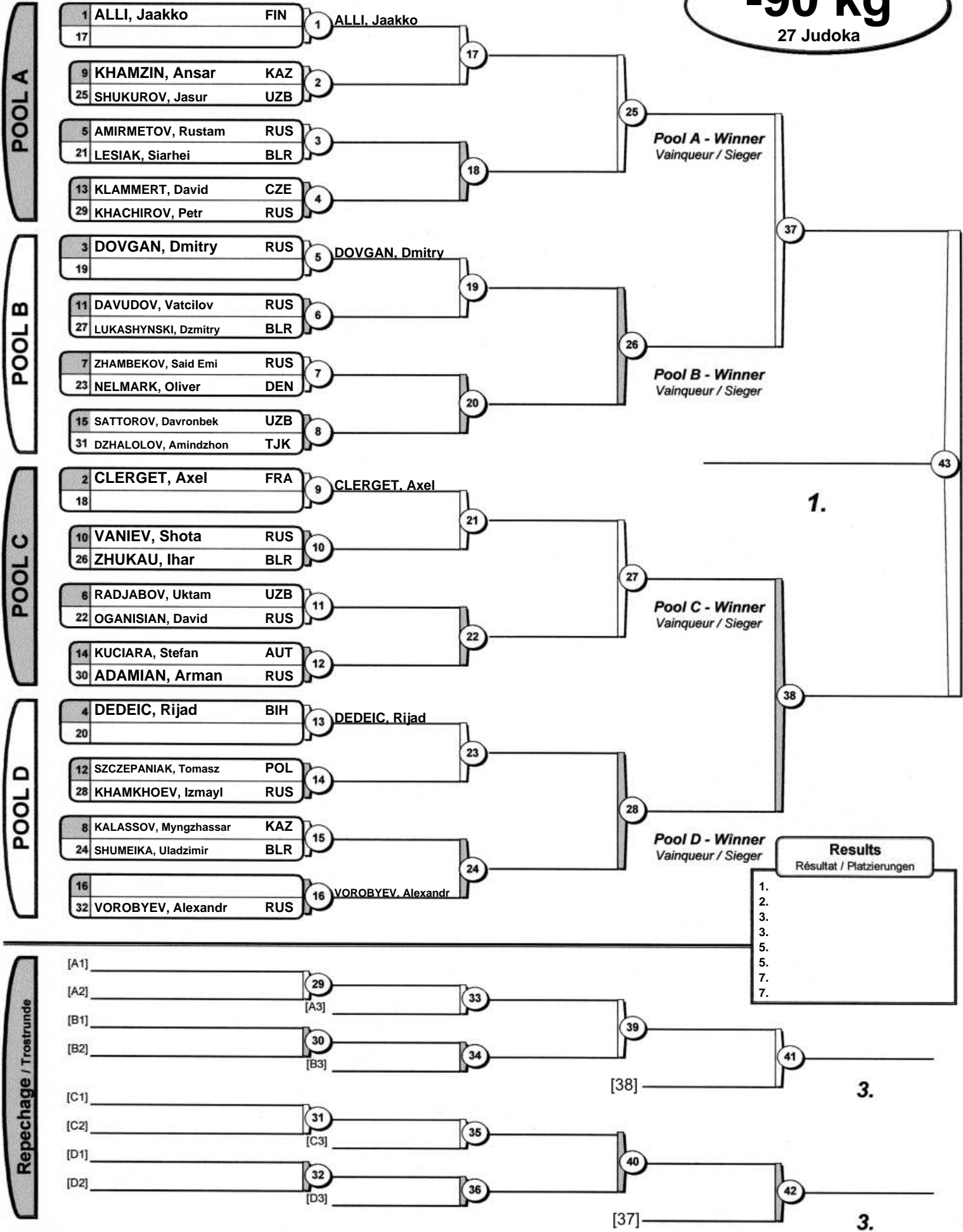

# European Judo Cup Orenburg 2015

Orenburg (RUS), 16-17 May 2015

## -100 kg

19 Judoka

POOL A

|    |                       |     |    |                       |
|----|-----------------------|-----|----|-----------------------|
| 1  | JOERGENSEN, Frederik  | DEN | 1  | JOERGENSEN, Frederik  |
| 17 |                       |     | 17 |                       |
| 9  | BASHAEV, Zelimkhan    | RUS | 2  |                       |
| 25 | TARAN, Mircea         | MDA | 2  |                       |
| 5  |                       |     | 3  | MALSUIGENOV, Ramazan  |
| 21 | MALSUIGENOV, Ramazan  | RUS | 3  |                       |
| 13 | BIKARYSTANOV, Nurzhan | KAZ | 4  | BIKARYSTANOV, Nurzhan |
| 29 |                       |     | 4  |                       |

Pool A - Winner  
Vainqueur / Sieger

POOL B

|    |                    |     |    |                    |
|----|--------------------|-----|----|--------------------|
| 3  | BILALOV, Niiaz     | RUS | 5  | BILALOV, Niiaz     |
| 19 |                    |     | 19 |                    |
| 11 | RUSTAMOV, Erbol    | UZB | 6  | RUSTAMOV, Erbol    |
| 27 |                    |     | 6  |                    |
| 7  | IKOEV, Soslan      | RUS | 7  |                    |
| 23 | FARA, Aaron        | AUT | 7  |                    |
| 15 |                    |     | 8  | MAMBETKULOV, Assan |
| 31 | MAMBETKULOV, Assan | KAZ | 8  |                    |

Pool B - Winner  
Vainqueur / Sieger

POOL C

|    |                   |     |    |                   |
|----|-------------------|-----|----|-------------------|
| 2  |                   |     | 9  | BALIANOV, Vitalii |
| 18 | BALIANOV, Vitalii | RUS | 9  |                   |
| 10 |                   |     | 10 | ZARZECZNY, Jakub  |
| 26 | ZARZECZNY, Jakub  | POL | 10 |                   |
| 6  | IVANOV, Filipp    | RUS | 11 | IVANOV, Filipp    |
| 22 |                   |     | 11 |                   |
| 14 | KNAPEK, Tomas     | CZE | 12 | KNAPEK, Tomas     |
| 30 |                   |     | 12 |                   |

Pool C - Winner  
Vainqueur / Sieger

POOL D

|    |                        |     |    |                        |
|----|------------------------|-----|----|------------------------|
| 4  | HAGENER, Maximilian    | AUT | 13 | HAGENER, Maximilian    |
| 20 |                        |     | 13 |                        |
| 12 | FESHCHENKO, Nikita     | RUS | 14 |                        |
| 28 | KOLBAY, Temirlan       | KAZ | 14 |                        |
| 8  |                        |     | 15 | BARKALAEV, Abdulmuslim |
| 24 | BARKALAEV, Abdulmuslim | RUS | 15 |                        |
| 16 |                        |     | 16 | ZHOLUDZEU, Mikita      |
| 32 | ZHOLUDZEU, Mikita      | BLR | 16 |                        |

Pool D - Winner  
Vainqueur / Sieger

1.

43

38

Results  
Résultat / Platzierungen

- 1.
- 2.
- 3.
- 3.
- 5.
- 7.
- 7.

3.

3.

Repechage / Trostrunde

|      |  |  |      |  |    |  |      |
|------|--|--|------|--|----|--|------|
| [A1] |  |  | 29   |  | 33 |  |      |
| [A2] |  |  | [A3] |  |    |  |      |
| [B1] |  |  | 30   |  | 34 |  | 39   |
| [B2] |  |  | [B3] |  |    |  | 41   |
| [C1] |  |  | 31   |  | 35 |  | [38] |
| [C2] |  |  | [C3] |  |    |  |      |
| [D1] |  |  | 32   |  | 36 |  | 40   |
| [D2] |  |  | [D3] |  |    |  | 42   |
|      |  |  |      |  |    |  | [37] |

# European Judo Cup Orenburg 2015

Orenburg (RUS), 16-17 May 2015

## +100 kg

17 Judoka

POOL A

|    |                       |     |    |                       |
|----|-----------------------|-----|----|-----------------------|
| 1  | KHAPTSEV, Atrur       | RUS | 1  | KHAPTSEV, Atrur       |
| 17 |                       |     | 17 |                       |
| 9  |                       |     | 2  | TUAEV, Soslan         |
| 25 | TUAEV, Soslan         | RUS | 2  | TUAEV, Soslan         |
| 5  | DOSMAGANBETOV, Nurbek | KAZ | 3  | DOSMAGANBETOV, Nurbek |
| 21 |                       |     | 18 |                       |
| 13 | IVANOV, Stepan        | RUS | 4  | IVANOV, Stepan        |
| 29 |                       |     | 4  | IVANOV, Stepan        |

Pool A - Winner  
Vainqueur / Sieger

POOL B

|    |                       |     |    |                       |
|----|-----------------------|-----|----|-----------------------|
| 3  |                       |     | 5  | BRACHEV, Anton        |
| 19 | BRACHEV, Anton        | RUS | 5  | BRACHEV, Anton        |
| 11 |                       |     | 6  | VAKHAVIAK, Aliaksandr |
| 27 | VAKHAVIAK, Aliaksandr | BLR | 6  | VAKHAVIAK, Aliaksandr |
| 7  | DIBRIN, Nikita        | RUS | 7  | DIBRIN, Nikita        |
| 23 |                       |     | 20 |                       |
| 15 | DAVIY, Alexey         | RUS | 8  |                       |
| 31 | TURABOEV, Shukhrat    | UZB | 8  |                       |

Pool B - Winner  
Vainqueur / Sieger

POOL C

|    |                      |     |    |                      |
|----|----------------------|-----|----|----------------------|
| 2  | MALISH, Akhmed       | RUS | 9  | MALISH, Akhmed       |
| 18 |                      |     | 21 |                      |
| 10 |                      |     | 10 | KAZHIBAYEV, Yerassyl |
| 26 | KAZHIBAYEV, Yerassyl | KAZ | 10 | KAZHIBAYEV, Yerassyl |
| 6  |                      |     | 11 | SUNDUKOV, Ivan       |
| 22 | SUNDUKOV, Ivan       | RUS | 11 | SUNDUKOV, Ivan       |
| 14 | ZALNOV, Evgenii      | RUS | 12 | ZALNOV, Evgenii      |
| 30 |                      |     | 12 | ZALNOV, Evgenii      |

Pool C - Winner  
Vainqueur / Sieger

POOL D

|    |                   |     |    |                   |
|----|-------------------|-----|----|-------------------|
| 4  | MASHARIPOV, Elyor | UZB | 13 | MASHARIPOV, Elyor |
| 20 |                   |     | 23 |                   |
| 12 | GASANOV, Alikhan  | RUS | 14 | GASANOV, Alikhan  |
| 28 |                   |     | 28 |                   |
| 8  |                   |     | 15 | JACKIEWICZ, Jan   |
| 24 | JACKIEWICZ, Jan   | POL | 15 | JACKIEWICZ, Jan   |
| 16 | SMEREKA, Edgardt  | RUS | 16 | SMEREKA, Edgardt  |
| 32 |                   |     | 24 |                   |

Pool D - Winner  
Vainqueur / Sieger

1.

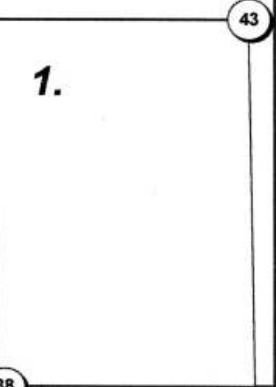

38

Results  
Résultat / Platzierungen

- 1.
- 2.
- 3.
- 3.
- 5.
- 7.
- 7.

Repechage / Trostrunde

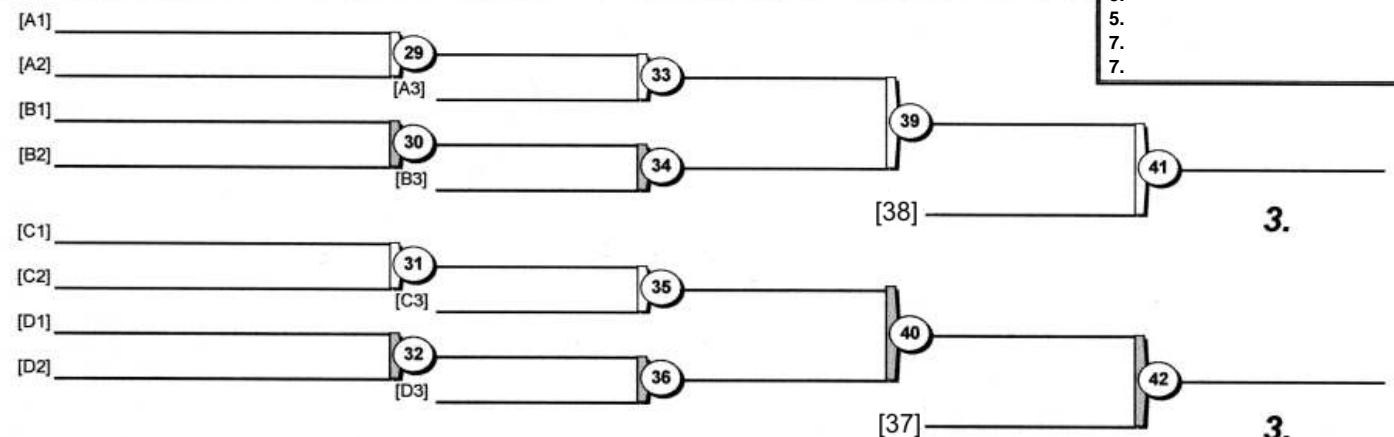

3.

3.

# European Judo Cup Orenburg 2015

Orenburg (RUS), 16-17 May 2015

## -48 kg

11 Judoka

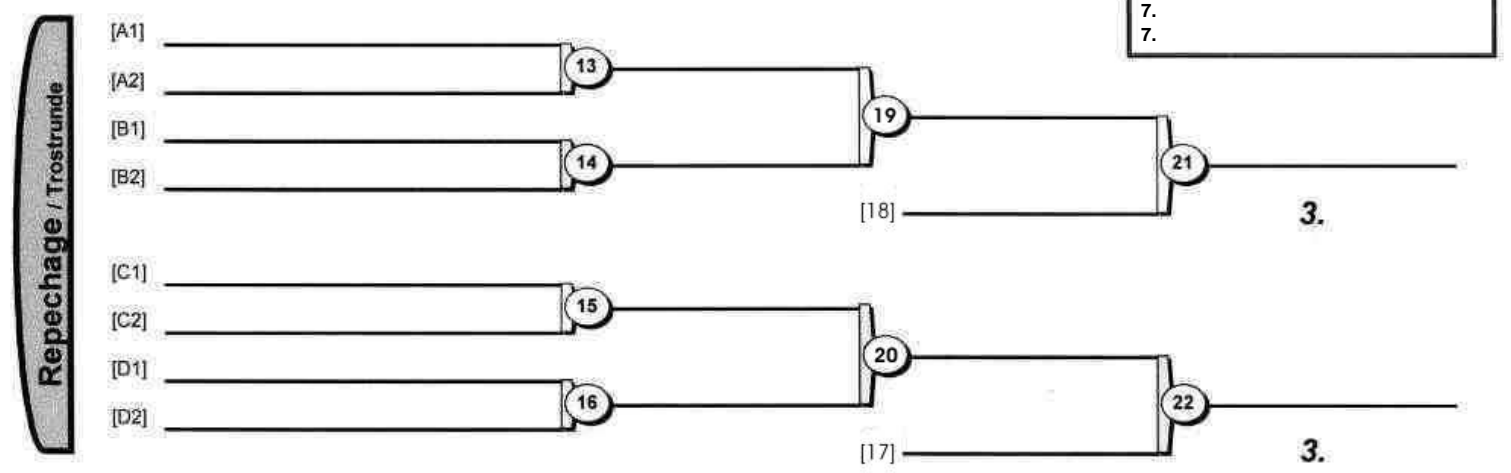
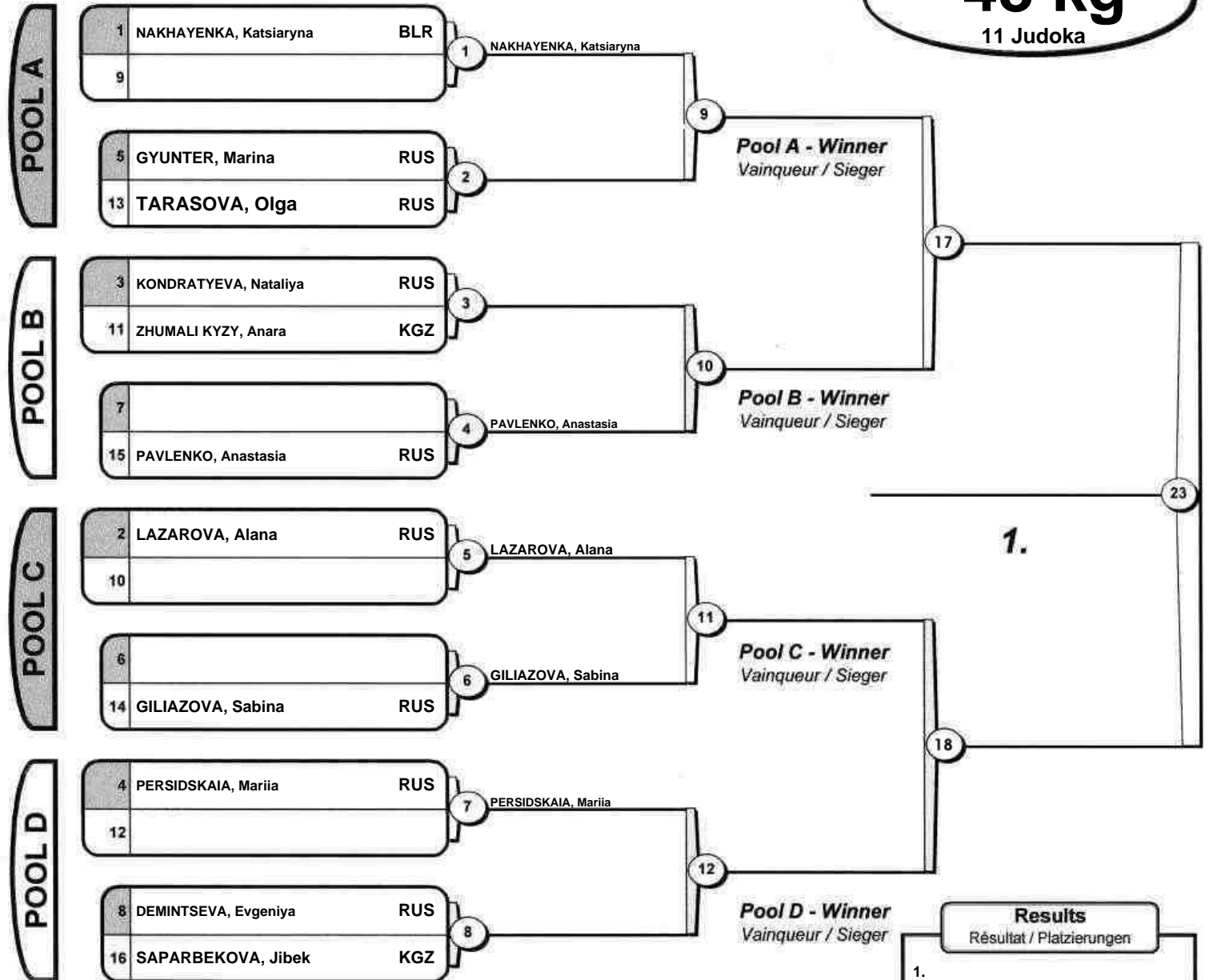



# European Judo Cup Orenburg 2015

Orenburg (RUS), 16-17 May 2015

## -52 kg

15 Judoka

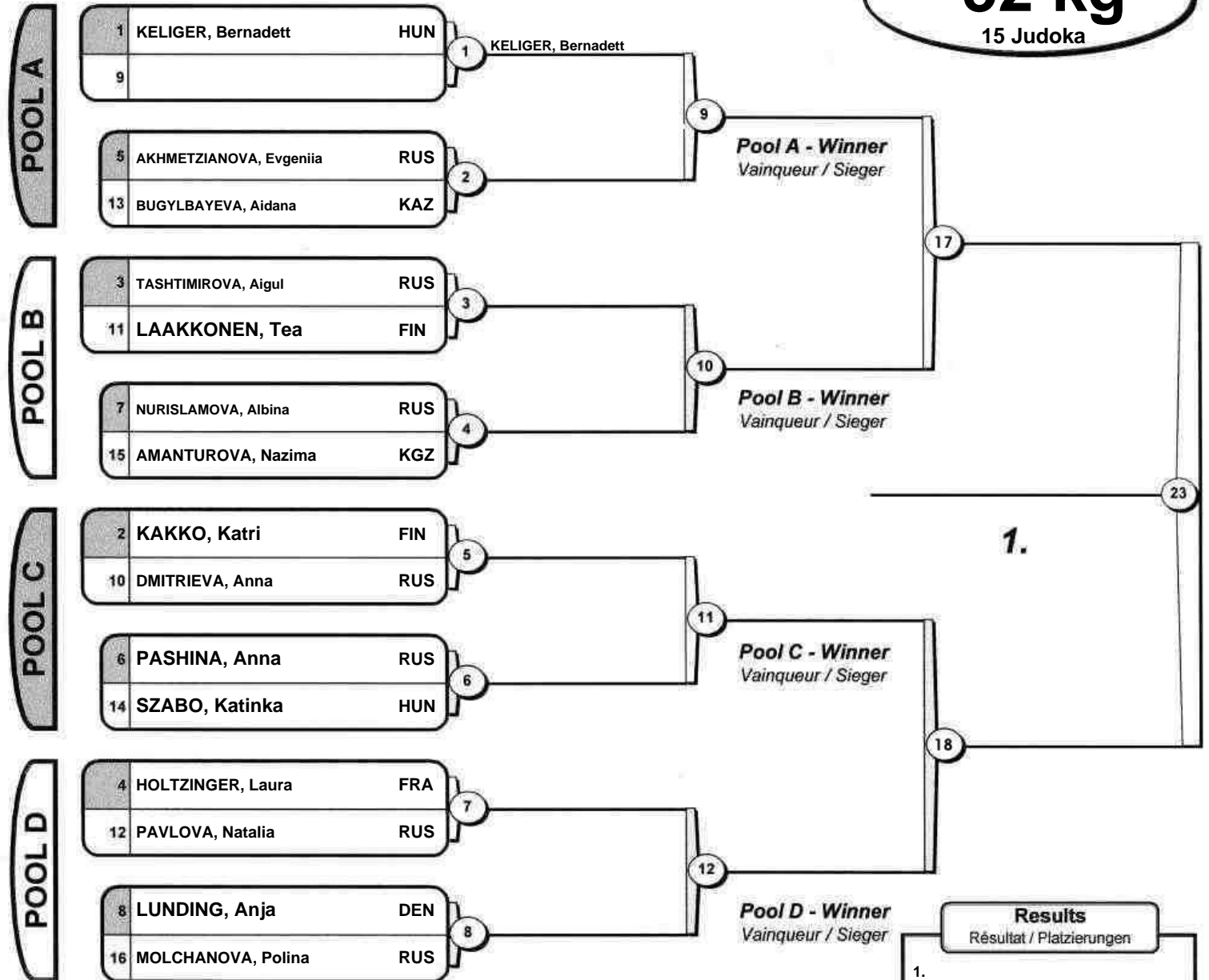

| Results                  |  |
|--------------------------|--|
| Résultat / Platzierungen |  |
| 1.                       |  |
| 2.                       |  |
| 3.                       |  |
| 3.                       |  |
| 5.                       |  |
| 5.                       |  |
| 7.                       |  |
| 7.                       |  |

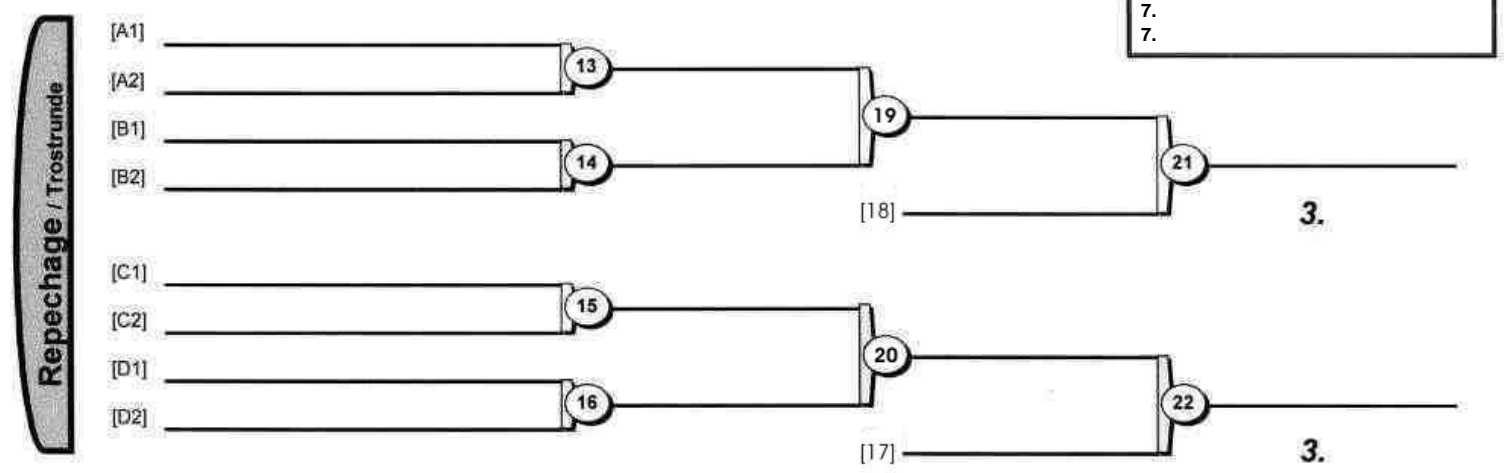

# European Judo Cup Orenburg 2015

Orenburg (RUS), 16-17 May 2015

## -57 kg

9 Judoka

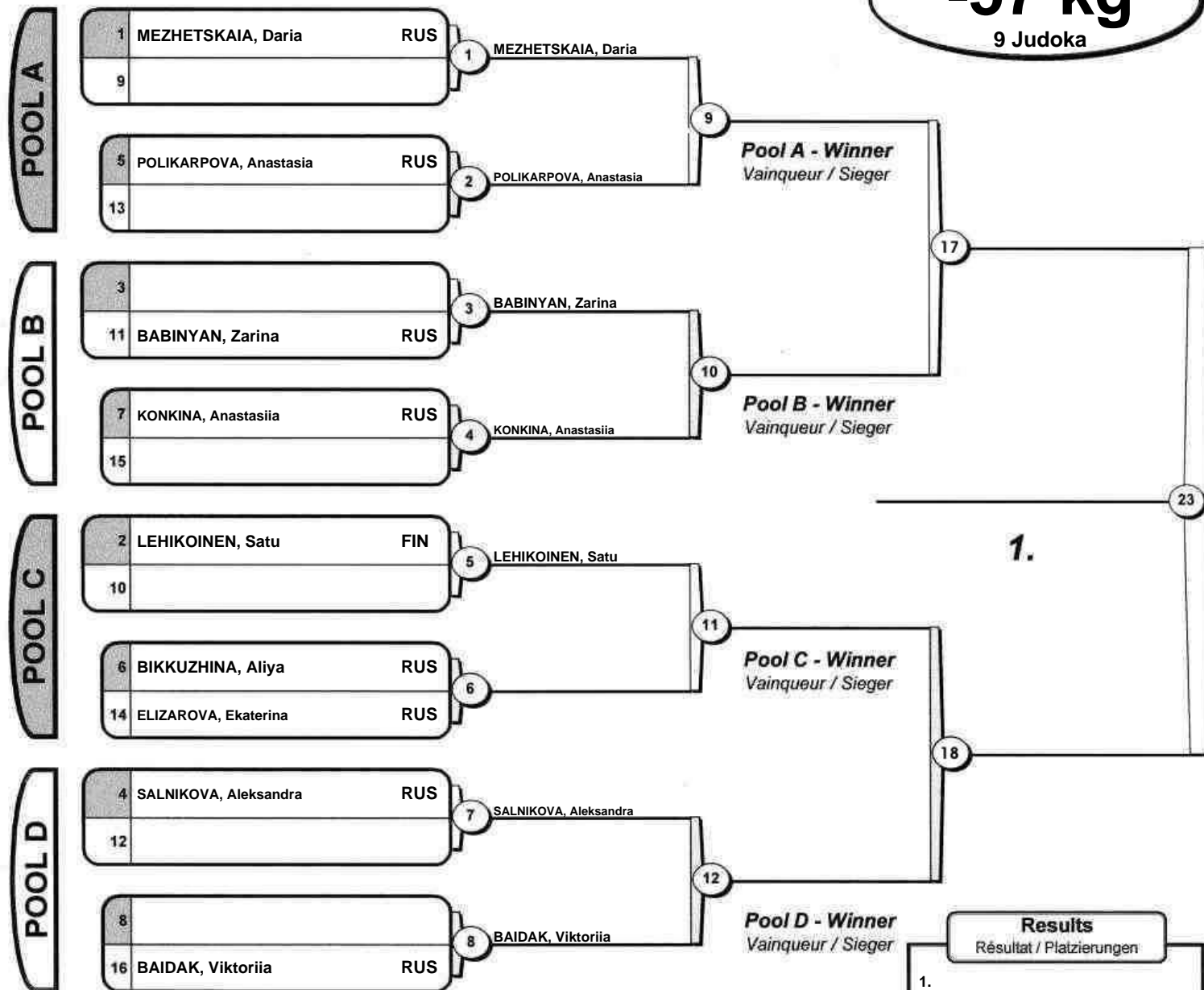

| Results                  |  |
|--------------------------|--|
| Résultat / Platzierungen |  |
| 1.                       |  |
| 2.                       |  |
| 3.                       |  |
| 3.                       |  |
| 5.                       |  |
| 5.                       |  |
| 7.                       |  |
| 7.                       |  |

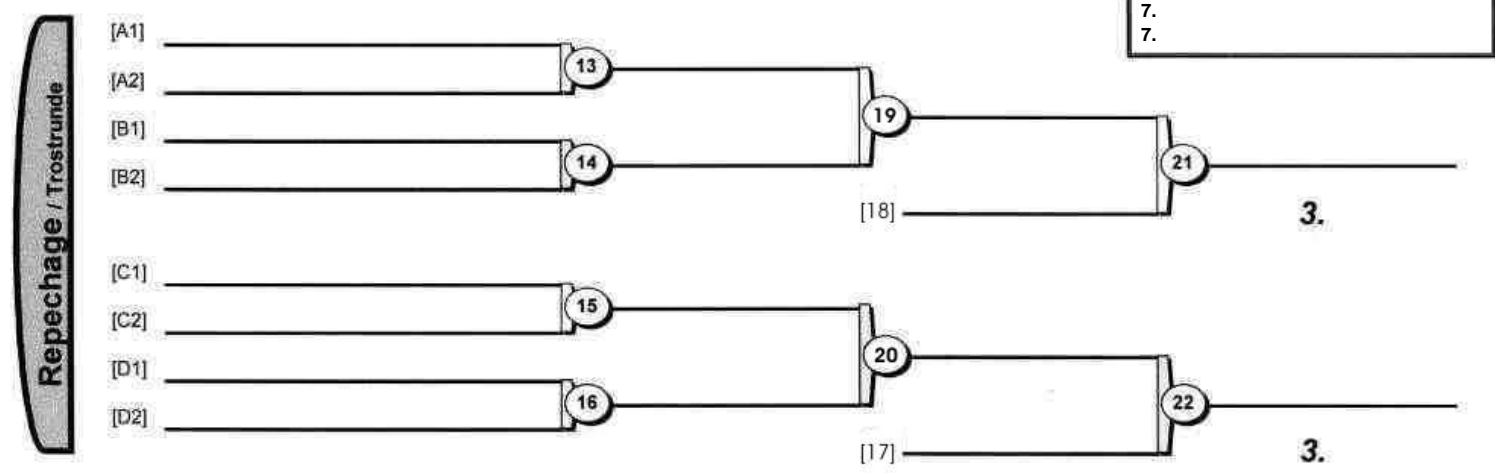

# European Judo Cup Orenburg 2015

Orenburg (RUS), 16-17 May 2015

## -63 kg

10 Judoka

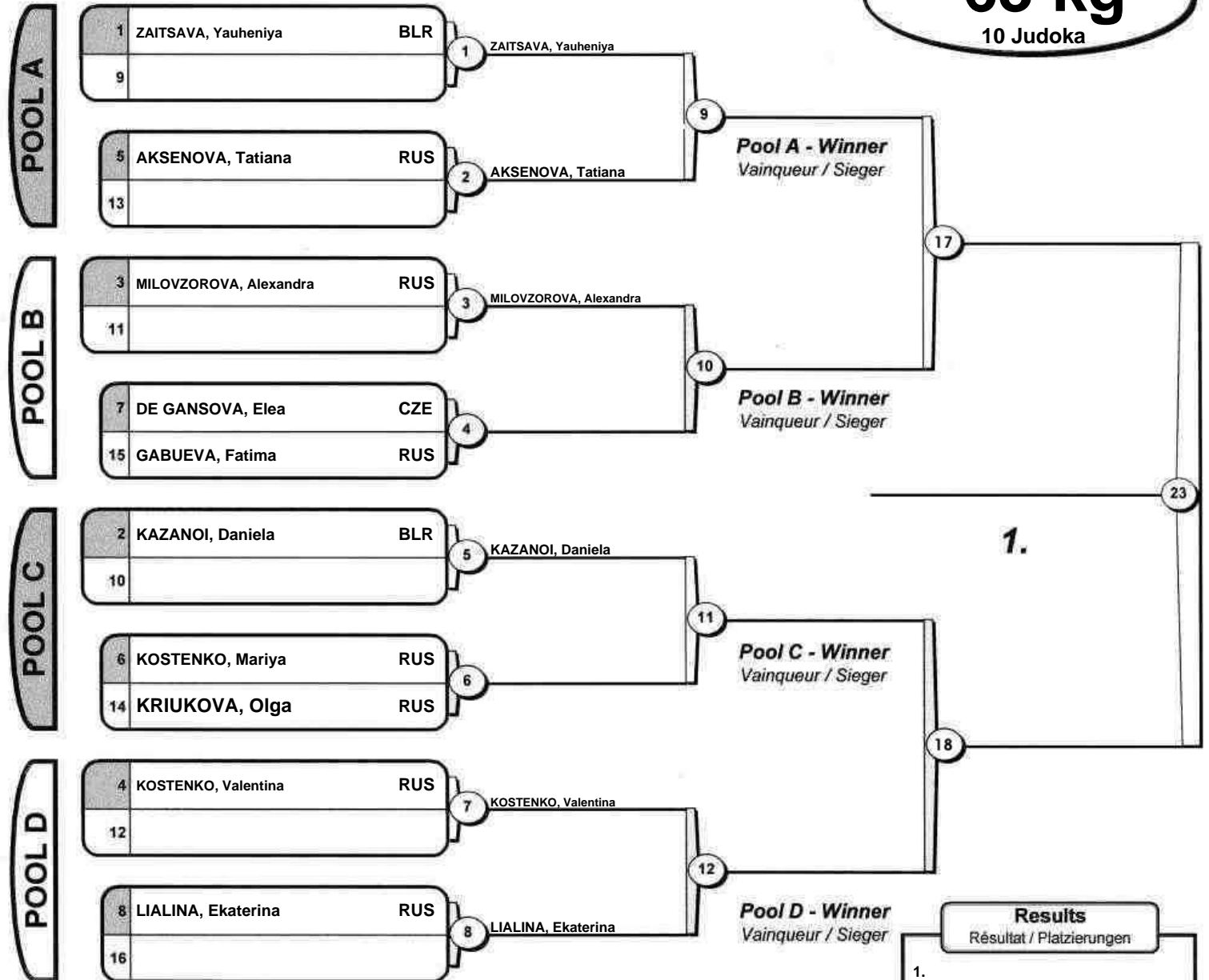

**Results**  
Résultat / Platzierungen

- 1.
- 2.
- 3.
- 3.
- 5.
- 5.
- 7.
- 7.

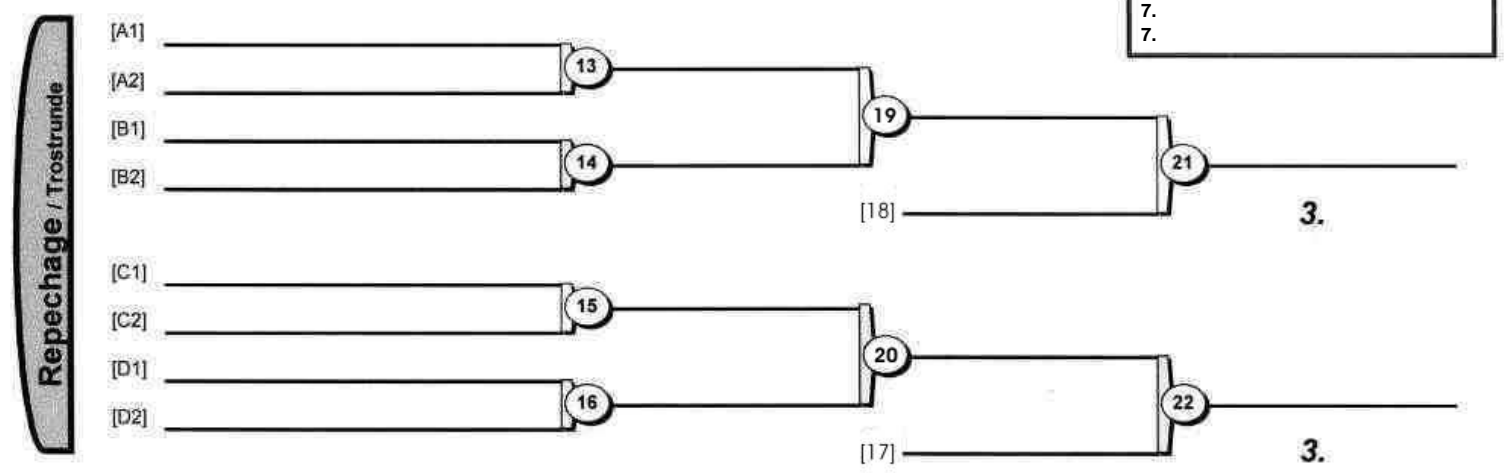

# European Judo Cup Orenburg 2015

Orenburg (RUS), 16-17 May 2015

## -70 kg

8 Judoka

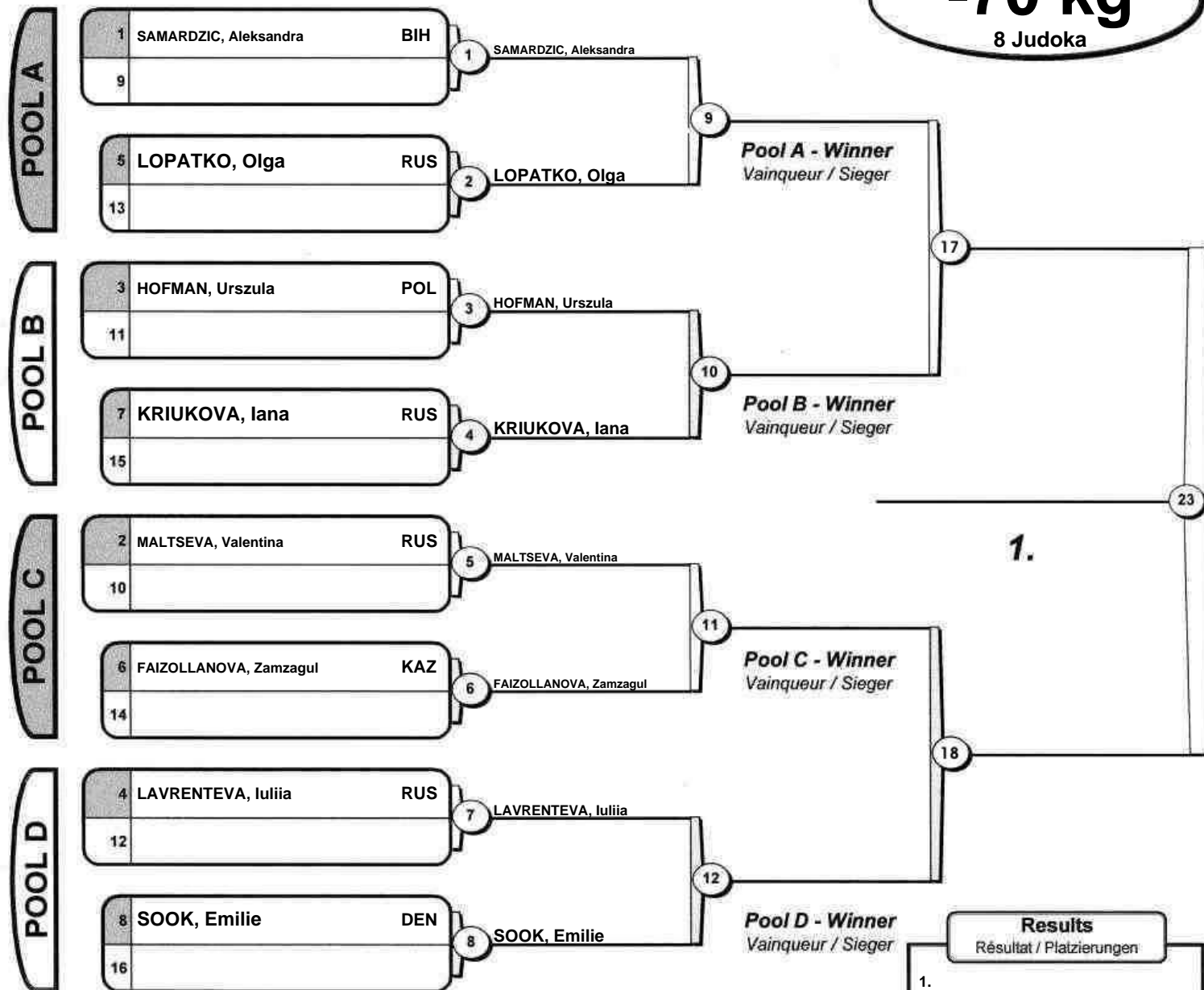

| Results                  |  |
|--------------------------|--|
| Résultat / Platzierungen |  |
| 1.                       |  |
| 2.                       |  |
| 3.                       |  |
| 3.                       |  |
| 5.                       |  |
| 5.                       |  |
| 7.                       |  |
| 7.                       |  |

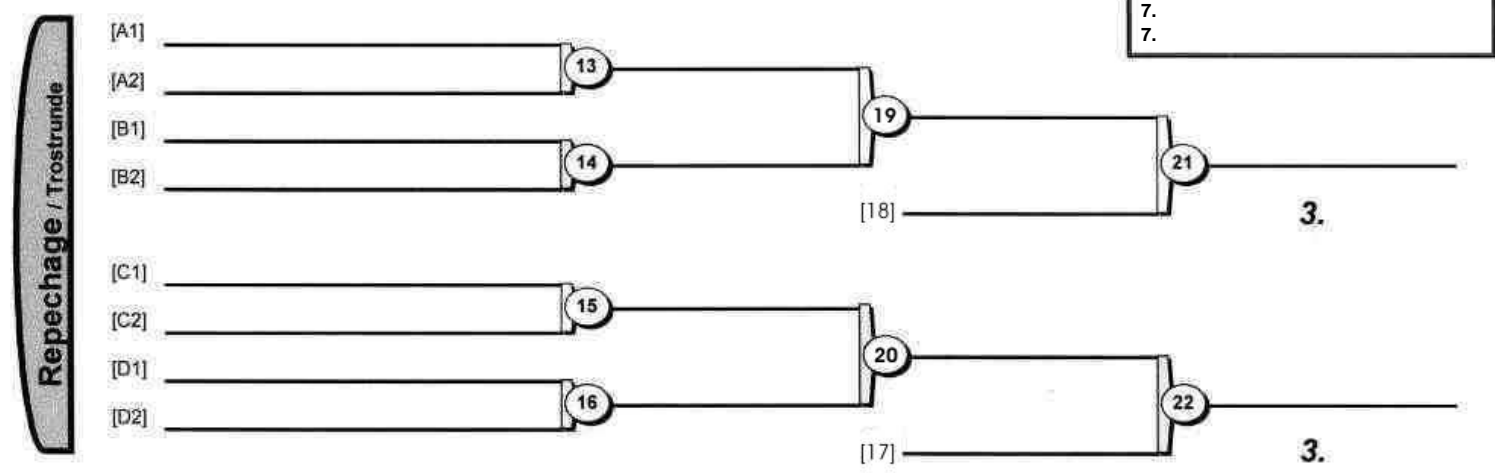

# European Judo Cup Orenburg 2015

Orenburg (RUS), 16-17 May 2015

## -78 kg

8 Judoka

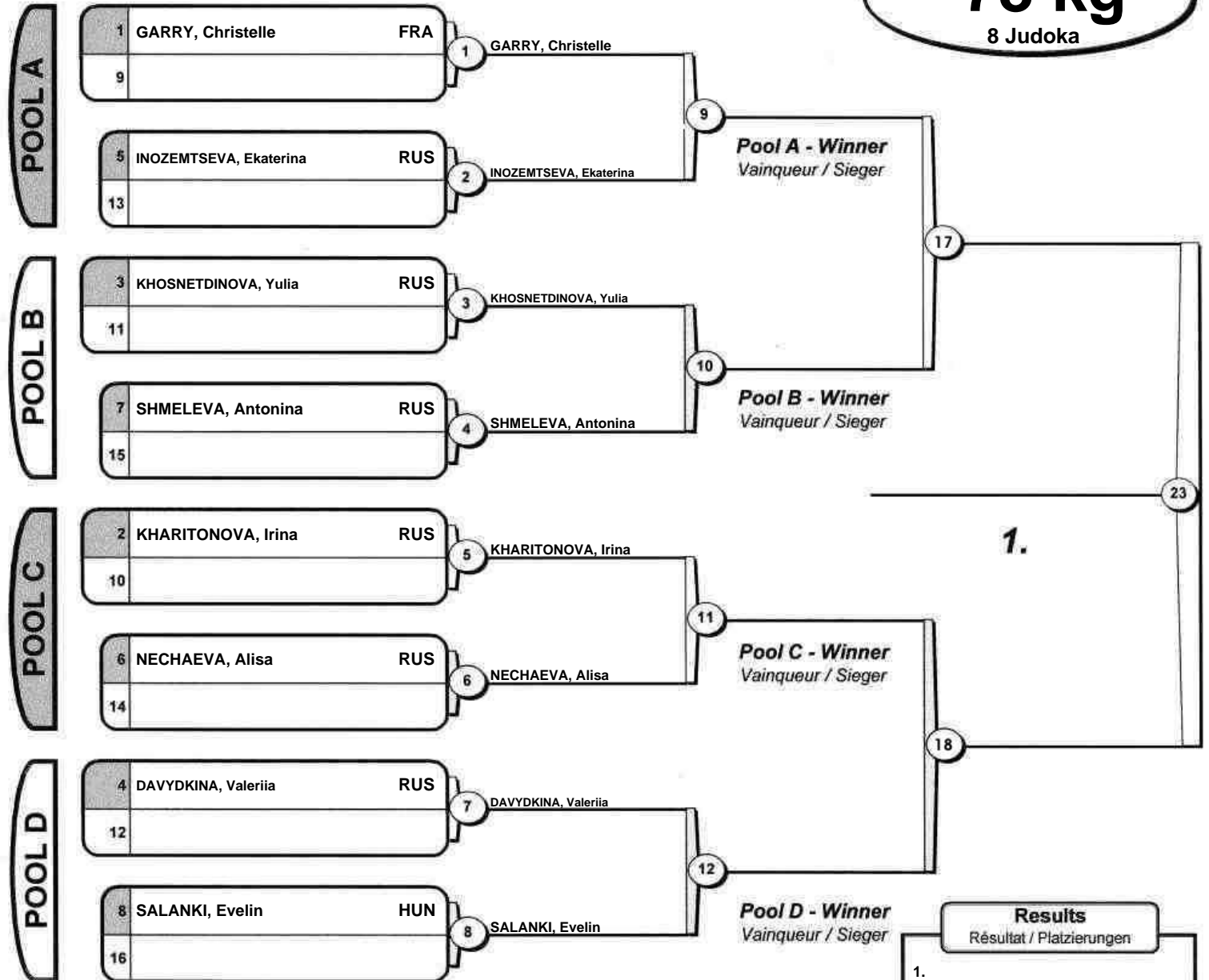

| Results                  |  |
|--------------------------|--|
| Résultat / Platzierungen |  |
| 1.                       |  |
| 2.                       |  |
| 3.                       |  |
| 3.                       |  |
| 5.                       |  |
| 5.                       |  |
| 7.                       |  |
| 7.                       |  |

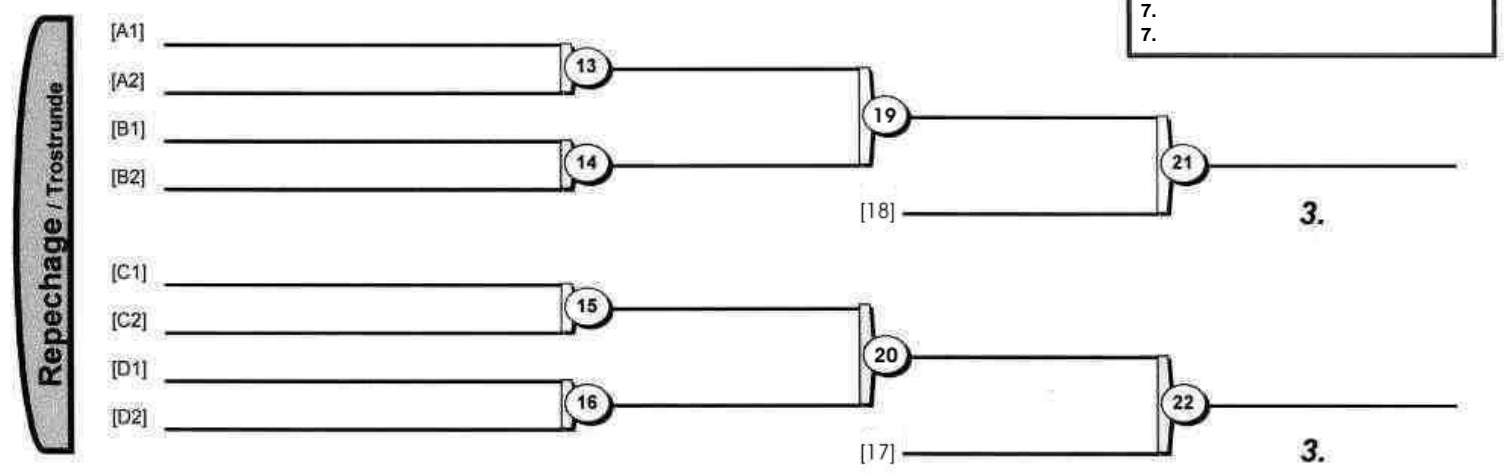

# European Judo Cup Orenburg 2015

Orenburg (RUS), 16-17 May 2015

## +78 kg

8 Judoka

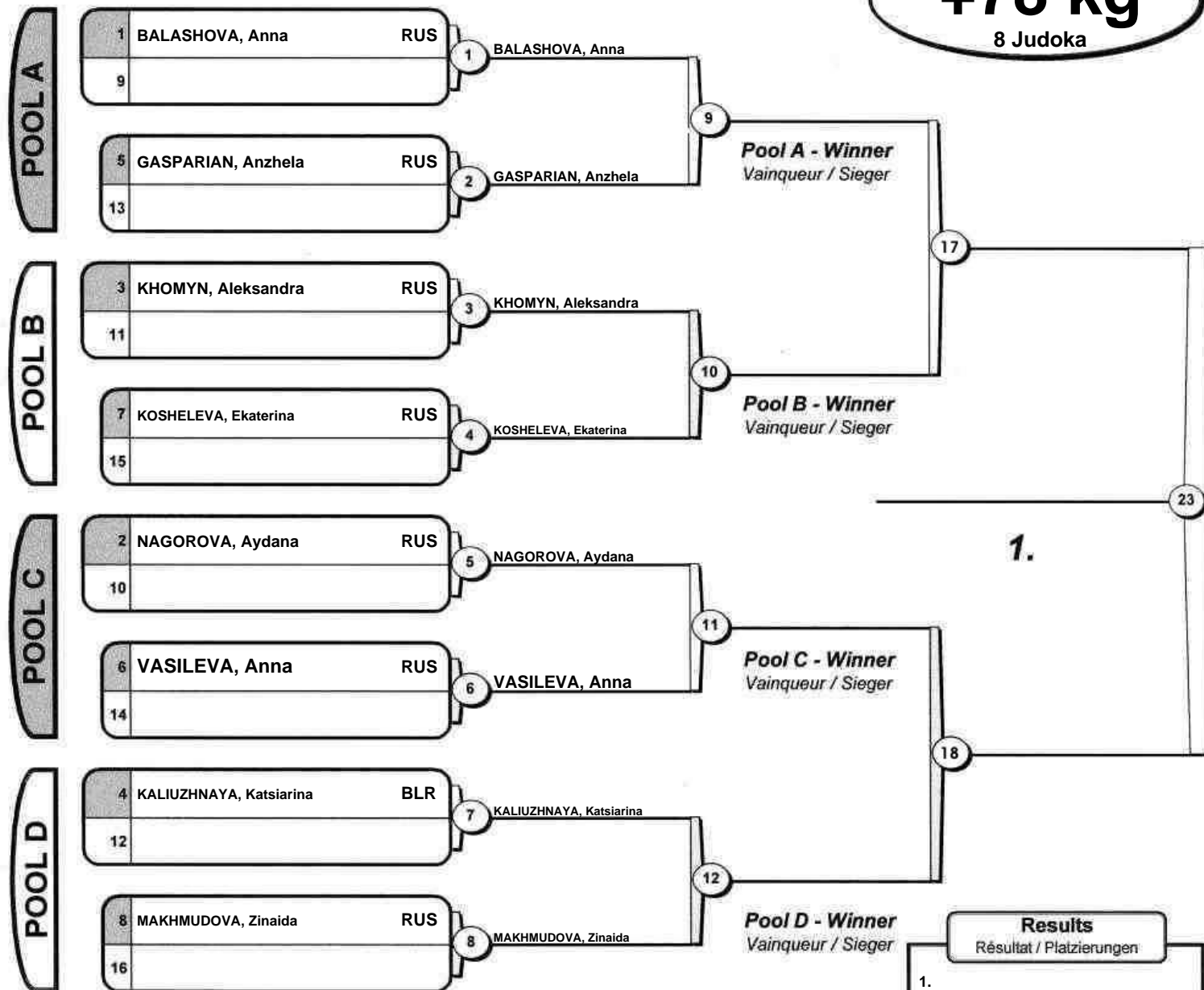

| Results                  |  |
|--------------------------|--|
| Résultat / Platzierungen |  |
| 1.                       |  |
| 2.                       |  |
| 3.                       |  |
| 3.                       |  |
| 5.                       |  |
| 5.                       |  |
| 7.                       |  |
| 7.                       |  |

